

Marine Transmission

TK 250

STANDARD SCOPE

- SAE housing #1 /#2 /#3
- Flexible coupling for 11,5" and 14" flywheel
- Mechanical control valve
- Oil strainer
- Trolling valve (mechanical or electrical)
- Oil filter mounted
- Oil cooler with thermostatic bypass valve
- Companion flange/bolts set
- Mounting brackets
- Shaft with key



Available Ratio's 2.0, 2.5,3.0
Max Input Torque: 61.8 (Kgf.m)
Dry Weight: 190 kg

ADVANTAGES OF TK 250

- 01 Greater durability through change of the rubber block made of special material.**
- 02 Hydraulic clutch can be easily handled outside.**
- 03 Control system fitted for a small-size ship and high speed.**
- 04 Guaranteed durability.**

SPECIFICATIONS

| Model | Reduction Ratio | Max. Input Speed (rpm) | Max. Input Torque (Kgf.m) | Input Rating | | | | | | | | | Dry Weight (Kg) | Flywheel Housing (SAE No.) | Flywheel (Clutch No.) |
|---------------|-----------------|------------------------|---------------------------|--------------|-----|-----|----------|-----|-----|----------|-----|-----|-----------------|----------------------------|-----------------------|
| | | | | 1600 rpm | | | 1800 rpm | | | 2100 rpm | | | | | |
| | | | | KW | HP | PS | KW | HP | PS | KW | HP | PS | | | |
| TK 250 | 2.0,2.5 3.0 | 3,000 | 61.8 | 114 | 154 | 156 | 133 | 179 | 182 | 152 | 204 | 207 | 190 | 1, 2, 3 | 11.5, 14 |

Marine Transmission

TK 250

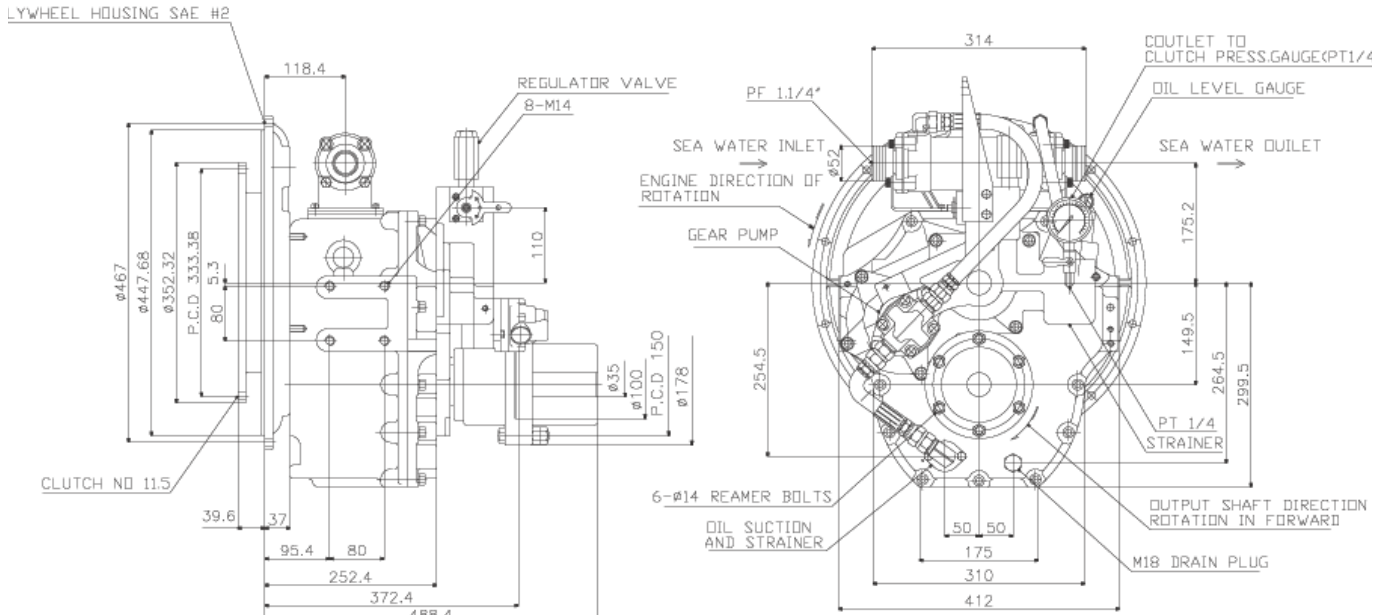
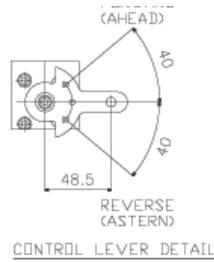

PRECAUTIONS

- Align the center of engine with marine gear (For greater effectiveness and longer lifespan)
- Install the supporting bracket of marine gear.
- When assembling flange on output shaft of marine gear, be sure to align another flange accurately.
- Make sure to wash flywheel housing cover if dust should accumulate.
- When installing the cable and the remote-control level, check to make sure the marine gear level is smooth.
- The oil with the viscosity equivalent to SAE#30 is recommended.
- Check the oil amount of oil before sailing.
- After 100 hours of operation check the oil, and then change every 1,000 hours.

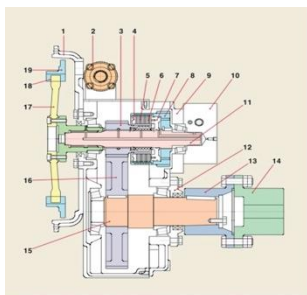

SECTIONAL DRAWING

- 1 Wheel Cover
- 2 Oil Cooler
- 3 Pinion Gear
- 4 Plate, Side
- 5 Plate, Sintered
- 6 Plate, Steel
- 7 Piston
- 8 Drum Gear
- 9 Block Cover
- 10 Control Block
- 11 Input Shaft
- 12 Retainer Cover
- 13 Coupling
- 14 Coupling Companion
- 15 Output Shaft
- 16 Reduction Gear
- 17 Spider
- 18 Rubber Block
- 19 Rubber Ring
- 20 Driving Ring

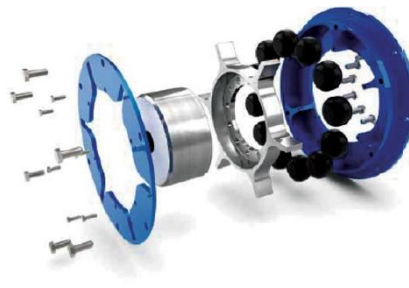

ADVANTAGES OF FLEXIBLE COUPLING

- 01 Plug-in Connection
- 02 Heat-Resistant up to 130°C
- 03 Fail-safe solution
- 04 Lubrication free
- 05 Rubber block solution