



WWW.AAM-EQUIPMENT.NL

MITSUBISHI

SPECIFICATIONS: S12R- PTAA2 1.650 KVA



Standard specifications

- Heavy-duty, water-cooled diesel engine
- Radiator with mechanical fan
- Protective grille for fan and rotating parts
- Electric starter and charge alternator
- Starting battery (with lead acid) including rack and cables
- Engine jacket water heater
- Steel base frame and anti-vibration isolators
- Fuel tank under the base frame
- Flexible fuel connection hoses
- Single bearing, class H alternator
- Industrial exhaust silencer and steel bellows supplied separately
- Static battery charger

- Manual for application and installation
- Generators Sets' voltage and frequency regulation comply with ISO 8528-5
- Generators Sets' can take 100% load at one step according to NFPA110

General characteristics

- Frequency (Hz) 50
- Engine Made and Model MITSUBISHI S12R-PTAA2
- Control Panel Model 7320
- Model Name APD 1650 M
- Fuel Type Diesel
- Alternator Made and Model ECO 46-1S/4 A
- Canopy AK 99- External removable silencer

POWER

VOLTAGE	STANDBY RATING ESP		PRIME RATING ESP		STANDBY AMPER
	kW	kVA	kW	kVA	
400/231	1320	1650	1200	1500	2381.64

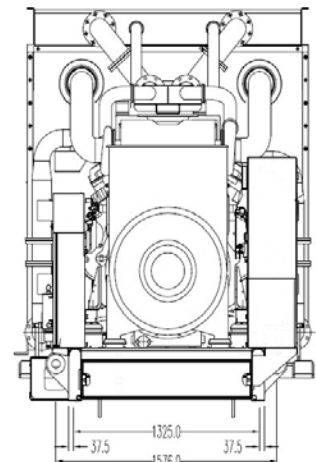
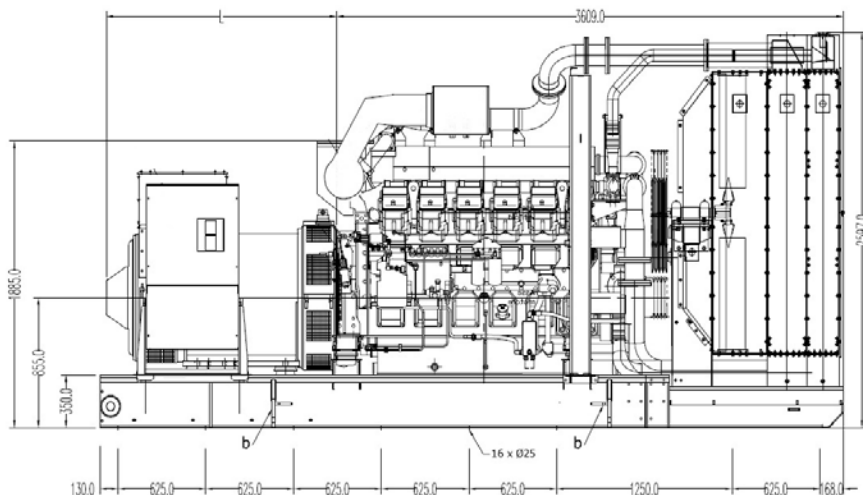



ENGINE SPECIFICATIONS

Engine	MITSUBISHI
Engine Model	S12R-PTAA2
Number of Cylinder (L)	12 cylinders – v type
Bore (mm.)	170
Stroke (mm.)	180
Displacement (lt.)	49.03
Aspiration	Turbo Charged and After Cooled
Compression Ratio	13.5:1
RPM (d/dk)	1500
Oil Capacity (Total With Filter) (lt)	180
Stand by Power kwm/hp (gross)	1441/1932
Prime Power kwm/hp (gross)	1314/1761
Block Heater QTY	2
Block Heater Power (Watt)	3000
Fuel Type	Diesel
Injection Type and System	Direct
Type of Fuel Pump	Mitsubishi PS6x2 (in-line)
Governor System	Electronic
Operating Voltage (Vdc)	24 Vdc
Battery and Capacity (Qty/Ah)	4x143
Charge Alternator (A)	30
Cooling Method	Water Cooled
Cooling Fan Air Flow (m3/min)	1800
Coolant Capacity (engine only / with radiator) (lt)	33/317
Air Filter	Dry Type
Fuel Cons. Prime With %100 Load (lt/hr)	308

ALTERNATOR CHARACTERISTICS

Manufacturer	Mecc Alte
Alternator Made and Model	ECO 46-1s/4A
Frequency (Hz)	50
Power (kVA)	1500
VOLTAGE (V)	400
Phase	3
A.V.R.	DER1
Voltage Regulation	(+/-)1%
Protection	H
Insulation System	IP21
Rated Power Factor	0.8

Open Gen. Set Dimensions (mm)

LENGHT	4980
WIDTH	2190
HEIGHT	3080
DRY WEIGHT (kg.)	11400
TANK CAPACITY (lt.)	2000/2200

Gen. Set Canopy Dimensions (mm)

LENGHT	9000
WIDTH	2800
HEIGHT	3300
DRY WEIGHT (kg.)	15450
TANK CAPACITY (lt.)	2000/2200

CONTROL PANEL

- Control Module DSE
- Control Module Model 7320
- Communication Ports MODBUS



1. MENU NAVIGATION BUTTONS
2. CLOSE MAINS BUTTOM
3. MAIN STATUS BUTTON
4. ALARM LED'S
5. CLOSE GENETATOR BUTTON
6. STATUS LED'S
7. OPERTION SELECTING BUTTONS

STANDARD SPECIFICATIONS

- Heavy duty, water cooled diesel engine
- Radiator with mechanical fan
- Protective grille for fan and rotating parts
- Electric starter and charge alternator
- Starting battery (with lead acid) including rack and cables
- Engine coolant heater
- Steel base frame and anti-vibration isolators
- Spare external fuel tank (open set)
- Flexible fuel connection hoses
- Single bearing, class H alternator
- Industrial exhaust silencer and steel bellows supplied separately
- Static battery charger
- Manual for application and installation
- Generators Sets' voltage and frequency regulation comply with ISO 8528-5
- Generators Sets' can take 100% load at one step according to NFPA110

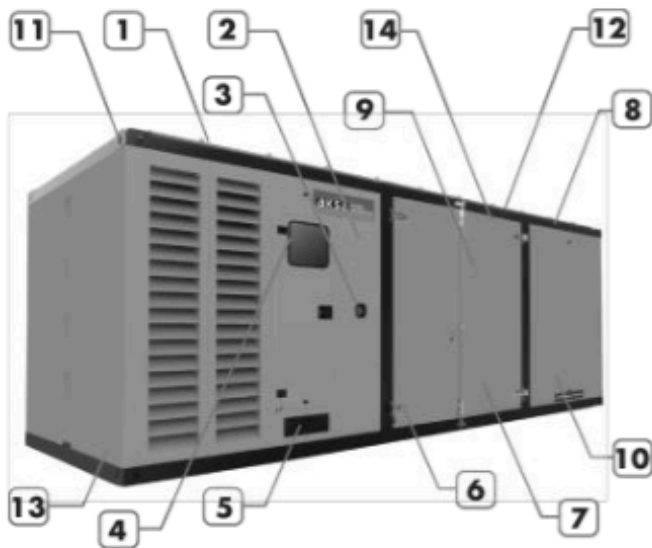

1. Steel structure made from steel sheet and steel profiles.
2. Canopy and panels made from powder coated sheet steel.
3. Emergency stop push button.
4. Control panel is mounted on the baseframe . Located at the back of the generator set
5. Cables out locations are under or back of the canopy.
6. Corrosion resistant locks and hinges.
7. Oil could be drained via valve and a hose
8. Exhaust system in the canopy.
9. Special large access doors for easy maintenance
10. Fuel tank is at front of the canopy ,easy access to the fuel tank via lockable door.
11. Lifting points similar to ISO container , located on each top corner of the canopy.
12. the cap on the canopy provides easy access to radiator cap.
13. sound proofing materials
14. Integrated ladder built in to side of the canopy allows access to the top of the canopy.

OPTIONAL EQUIPMENTS

ENGINE

- Remote Radiator Cooling
- Fuel-Water Separator Filter
- Oil heater

TRANSFER SWITCH

- Three or four pole contactor
- Three or four pole motor operated circuit breaker

OTHER ACCESSORIES

- Main Fuel Tank
- Automatic or manual fuel filling system

ALTERNATOR

- Anti-Condensation Heater
- Main line circuit breaker

CONTROL SYSTEM

- Automatic synchronizing and power control system (multi gen-set Parallel)
- Parallel system with mains.
- Transition synchronization with mains Remote relay output
- Alarm output relays