



### General data

<b>Maximum power*:</b>	90 kW (112,4 kVA)	<b>Voltage:</b>	400/230 V
<b>Prime Power**:</b>	82 kW	<b>Amperage:</b>	162,2 A
<b>Frequency:</b>	50 Hz	<b>Phases:</b>	3

### Dimensions and weights

<b>Total length without canopy:</b>	1770 mm	<b>Total length with canopy:</b>	2007 mm
<b>Total width without canopy:</b>	865 mm	<b>Total width with canopy:</b>	865 mm
<b>Total height without canopy:</b>	996 mm	<b>Total height with canopy:</b>	1048 mm
<b>Dry weight without canopy:</b>	1010 Kg	<b>Dry weight with canopy:</b>	1117 Kg

### Engine

<b>Base engine manufacturer:</b>	Deutz	<b>Diameter:</b>	108 mm (4,25 in)
<b>Model Solé Diesel:</b>	SDZ-165	<b>Stroke:</b>	130 mm (5,12 in)
<b>Type:</b>	4 stroke	<b>Compression ratio:</b>	19:1
<b>Engine RPM:</b>	1500	<b>Injection system:</b>	Mechanical and direct
<b>Number of cylinders:</b>	4	<b>Intake system:</b>	Turbocharged with intercooler
<b>Total displacement:</b>	4764 cc	<b>Flywheel housing:</b>	SAE 2
<b>Oil type:</b>	SAE 15W40	<b>Coolant capacity:</b>	17,5 L (4,62 gal)
<b>Oil capacity:</b>	11 L (2,91 gal)	<b>Flywheel:</b>	SAE 11 1/2
<b>Power:</b>	97 kW (131,92 CV)	<b>Coolant flow rate:</b>	141,5 l/min (37,38 gal/m)
<b>Salt water flow rate:</b>	107,4 l/min (28,37 gal/m)	<b>Intake air flow rate:</b>	6,1 m3/m

Rating conditions according to ISO 3046 (100 kPa barometric pressure, 30 % relative humidity and 25 °C (77 ° F))

\* Maximum output power: maximum power supplied by the genset at full load

\*\* Prime Power: rated power according to ISO 3046 and ISO 8528-1. 10 % overload capacity one hour in twelve hours.

1 kW  $\cong$  1,36 CV 1 kW  $\cong$  1,36 HP (metric) 1 kW  $\cong$  1,36 CH

## Fuel system details

<b>Consumption 25%:</b>	6,3 L/H (1,66 Gal/H)	<b>Fuel type:</b>	Diesel
<b>Consumption 50%:</b>	11,1 L/H (2,93 Gal/H)	<b>Fuel standards:</b>	Fueloil diesel ASTM
<b>Consumption 75%:</b>	16,2 L/H (4,28 Gal/H)	<b>Injection pump type:</b>	Individual
<b>Consumption 100%:</b>	21,5 L/H (5,68 Gal/H)	<b>Governor type:</b>	Mechanical

## Electrical system

<b>Battery voltage:</b>	24 V	<b>Stop solenoid type:</b>	ETS
<b>Starter motor:</b>	4 kW	<b>Alternator:</b>	35 A

## Installation details

<b>Exhaust hose inner diameter:</b>	90 mm (3,54 in)	<b>Maximum fuel lift height:</b>	1,3 m (4,27 ft)
<b>Sea water hose inner diameter:</b>	42 mm (1,65 in)	<b>Maximum raw water lift height:</b>	4 m (157,48 in)
<b>Fuel feeding hose inner diameter:</b>	12 mm (0,47 in)	<b>Maximum sea water temperature:</b>	32 °C (89,6 °F)
<b>Fuel return hose inner diameter:</b>	12 mm (0,47 in)	<b>Maximum installation angle***:</b>	10 °
<b>Minimum battery capacity:</b>	24 V 143 A/h		

## Alternator details

<b>Brand:</b>	Meccalte	<b>Cos φ:</b>	0,8
<b>Model:</b>	ECP34-1L/4A	<b>Tropicalized:</b>	Yes
<b>Regulator type:</b>	DSR	<b>Excitation system:</b>	Brushless
<b>Number of poles:</b>	4	<b>Voltage regulation accuracy**:</b>	1%
<b>Isolation type*:</b>	H	<b>Standards:</b>	EN60034-1, IEC 60034-1
<b>IP protection*:</b>	23	<b>Alternator type:</b>	Synchronous

## Optional accessories

Siphon break kit mandatory if generator is below waterline	Keel Cooling conversion for dry and wet exhaust
Engine electrical system at 24 V	Double walled pipes and alarm kit
Service/Cruise Kits: fuel and oil filters, raw water pump, impeller, alternator belt,...	Low coolant level shut down switch
Dry Exhaust system	Fuel filter/water separator
Exhaust System	Gas/Water Separator
Water Filters	Fuel Hose
Sea water cock	Exhaust Hose
Welcome Kit	Raw water hose



\* Other protections available

\*\* With load from 0 to 100%, speed variation from -2% up to +5%, power factor 0,8 linear and balanced load.

\*\*\* In all directions

For other requirements please contact the Sales Dept.

# SCO 10 PANEL



## General Description

- Graphic LCD with light, 128 x 64 pixels display
- 70 LED indicators
- Genset Measures (see Display Information)
- Configuration protected by password
- Running hour indication
- Multilanguage
- Genset protections (see Alarm Management)
- Preheating function
- D+ pre-excitation Terminal
- CAN bus information output with SAE J1939 protocol
- Two multipurpose timers
- Dimensions 180 x 120 x 55 mm
- Weight 450 g

## Alarm Management

### Shut Downs (SD)

- High coolant temperature
- Low oil pressure
- Overspeed
- Overload\*
- Short circuit\*
- Overcurrent\*
- Over/Under voltage
- Over/Under frequency
- Emergency stop

### Warnings (WRN)

- High coolant temperature
- Low oil pressure
- Over/Under voltage
- Maintenance request

### Sensor fails (FLS)

## Function Description

- OFF Mode
- MAN Mode (manual start/stop engine)
- AUT Mode (auto start/stop engine)



## Power Supply

- Voltage supply 12/24 DC with fuse protection
- Consumption 60/35 mA

## Operating Conditions

- Operating temperature -20+70 °C
- Humidity 95 % Without condensation
- Front Panel Protection IP65

## Standard Conformity

- Low Voltage Directive EN 61010-1:95+A1:97
- Electromagnetic EN 50081-1:94, EN 50081-2:96
- Compatibility EN 50082-1:99, EN 50082-2:97

## Display Information

### Measurement

- L1-L3 Voltage (V), Frequency (Hz), Oil Pressure, (bar)
- Coolant Temperature (°C), Battery, Voltage (V), RPM
- Active Power\* (kW), Apparent, Power\* (kVA), Current\* (A), PF\*

### History log

## Optional Equipment

### SCO 10 Double panel

- Allows the same operation and functionality as main SCO 10
- They are connected by RS485 port
- Communication wire available in 12/24/36 m.

### IP65 Box Kit

- Electrical Box panel with an IP65 protection code
- Emergency stop button and an on/off panel power switch

### Binary Input/Output extension module

### IG-IB Internet communication bridge

- For Ethernet/Internet communications

### Current transformers

#### Allow the following readings:

- Current (A), Active Power (kW), Apparent power (kVA) and PF
- Earth isolated transformers
- Voltage transformer to separate main voltage
- Voltage ratio controller (1:1)

\* The specified function needs the current transformers (Optional Equipment) for showing the information in panel display.

## Dimensions

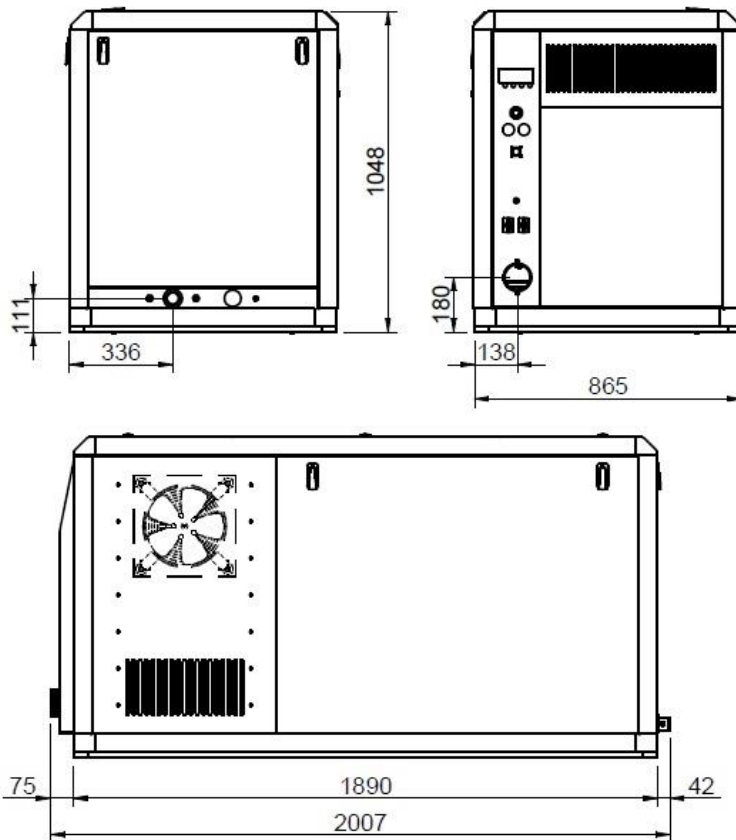
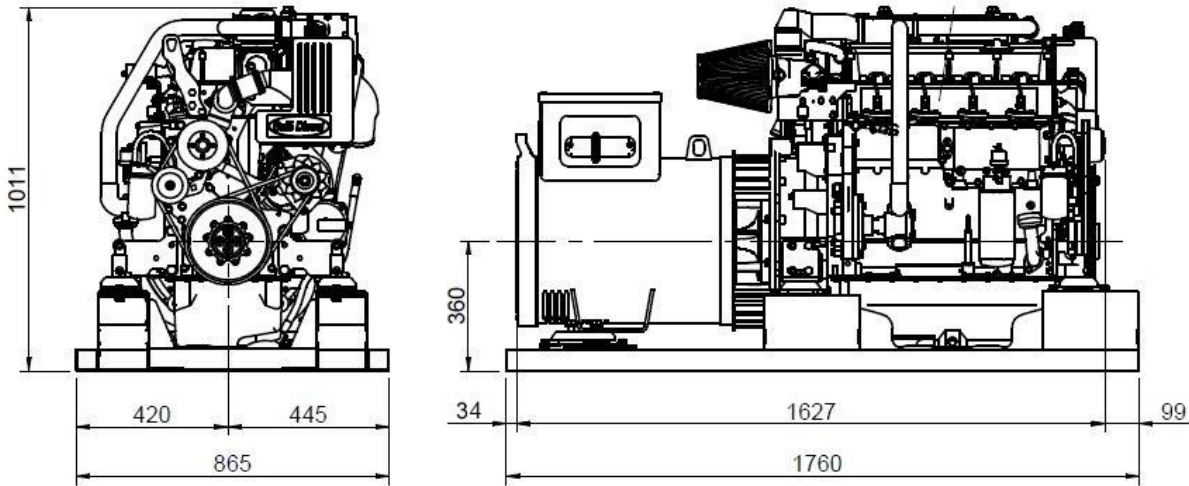

Authorized dealer

[www.solediesel.com](http://www.solediesel.com)  
[info@solediesel.com](mailto:info@solediesel.com)

Detailed drawings, brochures and manuals are available on the web [solediesel.com](http://www.solediesel.com). All rights reserved. Technical specifications, data and presentation are subjected to variations, changes and updates without prior notice. Non-contractual information.