

MARINE GENERATORS
45 GT/GTC

Three-Phase



General data

Maximum power*:	36 kW (45 kVA)	Voltage:	400/230 V
Prime Power**:	32,7 kW	Amperage:	65 A
Frequency:	50 Hz	Phases:	3

Dimensions and weights

Total length without canopy:	1428 mm	Total length with canopy:	1605 mm
Total width without canopy:	740 mm	Total width with canopy:	740 mm
Total height without canopy:	785 mm	Total height with canopy:	841 mm
Dry weight without canopy:	560 Kg	Dry weight with canopy:	598 Kg

Engine

Base engine manufacturer:	Mitsubishi	Diameter:	94 mm (3,7 in)
Model Solé Diesel:	SM-56	Stroke:	120 mm (4,72 in)
Type:	4 stroke	Compression ratio:	17:1
Engine RPM:	1500	Injection system:	Mechanical and direct
Number of cylinders:	4	Intake system:	Turbocharged
Total displacement:	3331 cc	Flywheel housing:	SAE 3
Oil type:	SAE 15W40	Coolant capacity:	13 L (3,43 gal)
Oil capacity:	10 L (2,64 gal)	Flywheel:	SAE 11 1/2
Power:	40,5 kW (55,08 CV)	Coolant flow rate:	105 l/min (27,74 gal/m)
Salt water flow rate:	38 l/min (10,04 gal/m)	Intake air flow rate:	2,9 m3/m

Rating conditions according to ISO 3046 (100 kPa barometric pressure, 30 % relative humidity and 25 °C (77 ° F))

* Maximum output power: maximum power supplied by the genset at full load

** Prime Power: rated power according to ISO 3046 and ISO 8528-1. 10 % overload capacity one hour in twelve hours.

1 kW \cong 1,36 CV 1 kW \cong 1,36 HP (metric) 1 kW \cong 1,36 CH

Fuel system details

Consumption 25%:	3,2 L/H (0,85 Gal/H)	Fuel type:	Diesel
Consumption 50%:	5,2 L/H (1,37 Gal/H)	Fuel standards:	Fueloil diesel ASTM
Consumption 75%:	7,4 L/H (1,95 Gal/H)	Injection pump type:	in line
Consumption 100%:	9,7 L/H (2,56 Gal/H)	Governor type:	Mechanical

Electrical system

Battery voltage:	12 V	Stop solenoid type:	ETR
Starter motor:	2,2 kW	Alternator:	50 A

Installation details

Exhaust hose inner diameter:	75 mm (2,95 in)	Maximum fuel lift height:	0,3 m (0,98 ft)
Sea water hose inner diameter:	32 mm (1,26 in)	Maximum raw water lift height:	2,5 m (98,43 in)
Fuel feeding hose inner diameter:	8 mm (0,31 in)	Maximum sea water temperature:	32 °C (89,6 °F)
Fuel return hose inner diameter:	8 mm (0,31 in)	Maximum installation angle***:	15 °
Minimum battery capacity:	12 V 95 A/h		

Alternator details

Brand:	Meccalte	Cos φ:	0,8
Model:	ECP32-1M/4B	Tropicalized:	Yes
Regulator type:	DSR	Excitation system:	Brushless
Number of poles:	4	Voltage regulation accuracy**:	1%
Isolation type*:	H	Standards:	EN60034-1, IEC 60034-1
IP protection*:	23	Alternator type:	Synchronous

Optional accessories

Siphon break kit mandatory if generator is below waterline	Keel Cooling conversion for dry and wet exhaust
Engine electrical system at 24 V	Double walled pipes and alarm kit
Service/Cruise Kits: fuel and oil filters, raw water pump, impeller, alternator belt,...	Low coolant level shut down switch
Dry Exhaust system	Fuel filter/water separator
Exhaust System	Gas/Water Separator
Water Filters	Fuel Hose
Sea water cock	Exhaust Hose
Welcome Kit	Raw water hose



* Other protections available

** With load from 0 to 100%, speed variation from -2% up to +5%, power factor 0,8 linear and balanced load.

*** In all directions

For other requirements please contact the Sales Dept.

SCO 10 PANEL



General Description

- Graphic LCD with light, 128 x 64 pixels display
- 70 LED indicators
- Genset Measures (see Display Information)
- Configuration protected by password
- Running hour indication
- Multilanguage
- Genset protections (see Alarm Management)
- Preheating function
- D+ pre-excitation Terminal
- CAN bus information output with SAE J1939 protocol
- Two multipurpose timers
- Dimensions 180 x 120 x 55 mm
- Weight 450 g

Alarm Management

Shut Downs (SD)

- High coolant temperature
- Low oil pressure
- Overspeed
- Overload*
- Short circuit*
- Overcurrent*
- Over/Under voltage
- Over/Under frequency
- Emergency stop

Warnings (WRN)

- High coolant temperature
- Low oil pressure
- Over/Under voltage
- Maintenance request

Sensor fails (FLS)

Function Description

- OFF Mode
- MAN Mode (manual start/stop engine)
- AUT Mode (auto start/stop engine)



Power Supply

- Voltage supply 12/24 DC with fuse protection
- Consumption 60/35 mA

Operating Conditions

- Operating temperature -20+70 °C
- Humidity 95 % Without condensation
- Front Panel Protection IP65

Standard Conformity

- Low Voltage Directive EN 61010-1:95+A1:97
- Electromagnetic EN 50081-1:94, EN 50081-2:96
- Compatibility EN 50082-1:99, EN 50082-2:97

Display Information

Measurement

- L1-L3 Voltage (V), Frequency (Hz), Oil Pressure, (bar)
- Coolant Temperature (°C), Battery, Voltage (V), RPM
- Active Power* (kW), Apparent, Power* (kVA), Current* (A), PF*

History log

Optional Equipment

SCO 10 Double panel

- Allows the same operation and functionality as main SCO 10
- They are connected by RS485 port
- Communication wire available in 12/24/36 m.

IP65 Box Kit

- Electrical Box panel with an IP65 protection code
- Emergency stop button and an on/off panel power switch

Binary Input/Output extension module

IG-IB Internet communication bridge

- For Ethernet/Internet communications

Current transformers

Allow the following readings:

- Current (A), Active Power (kW), Apparent power (kVA) and PF
- Earth isolated transformers
- Voltage transformer to separate main voltage
- Voltage ratio controller (1:1)

* The specified function needs the current transformers (Optional Equipment) for showing the information in panel display.

Dimensions

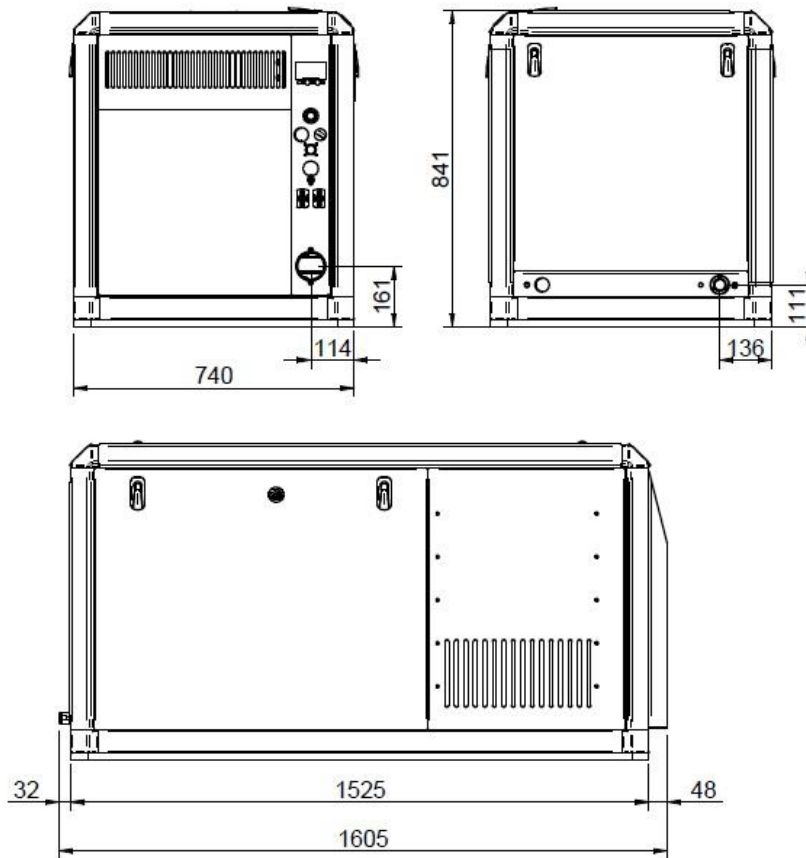
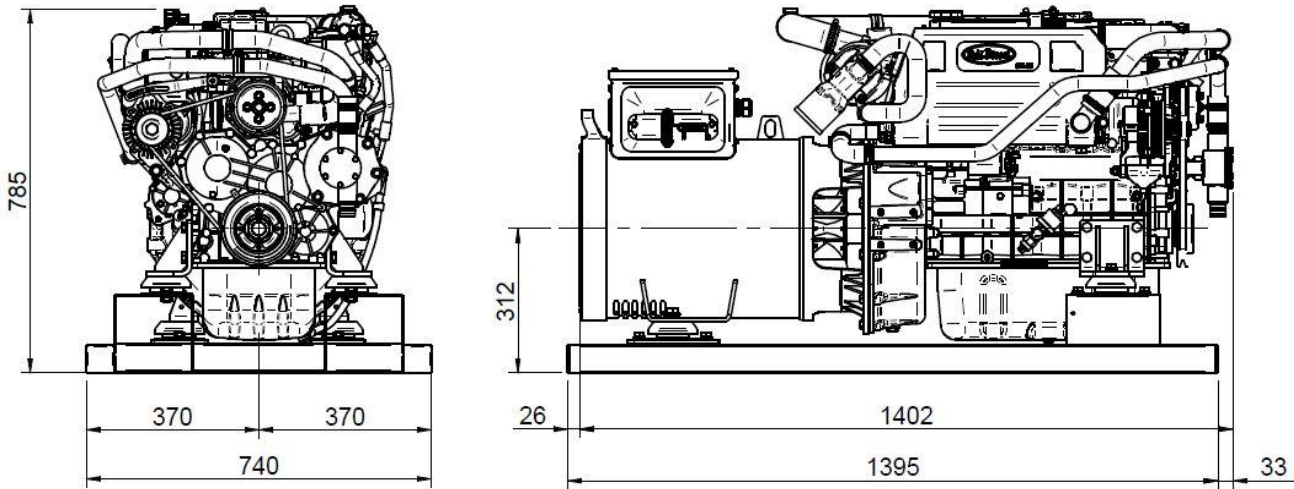

Authorized dealer

www.solediesel.com
info@solediesel.com

Detailed drawings, brochures and manuals are available on the web [solediesel.com](http://www.solediesel.com). All rights reserved. Technical specifications, data and presentation are subjected to variations, changes and updates without prior notice. Non-contractual information.