

# Marine Transmission

## TK 750 L

### STANDARD SCOPE

- SAE housing #0/ #1
- Flexible coupling for 14"/18" flywheel
- Mechanical control valve
- Oil strainer
- Trolling valve (mechanical or electrical)
- Oil filter mounted
- Oil cooler with thermostatic bypass valve
- Companion flange/bolts set
- Mounting brackets
- Shaft with key



**Available Ratio's**      3.46, 4.04 , 4.44  
**Max Input Torque:**    298.5(Kgf.m)  
**Dry Weight:**            720 kg

### ADVANTAGES OF TK 750 L

- 01 Greater durability through change of the rubber block made of special material.**
- 02 Hydraulic clutch can be easily handled outside.**
- 03 Control system fitted for a small-size ship and high speed.**
- 04 Guaranteed durability.**

### SPECIFICATIONS

Model	Reduction Ratio	Max. Input Speed (rpm)	Max. Input Torque (Kgf.m)	Input Rating									Dry Weight (Kg)	Flywheel Housing (SAE No.)	Flywheel (Clutch No.)
				1600 rpm			1800 rpm			2100 rpm					
				KW	HP	PS	KW	HP	PS	KW	HP	PS			
<b>TK 750 L</b>	3.46, 4.04 4.44	2,400	298.5	491	658	667	552	740	750	644	863	875	720	#0 / #1	14/18

# Marine Transmission

## TK 750 L

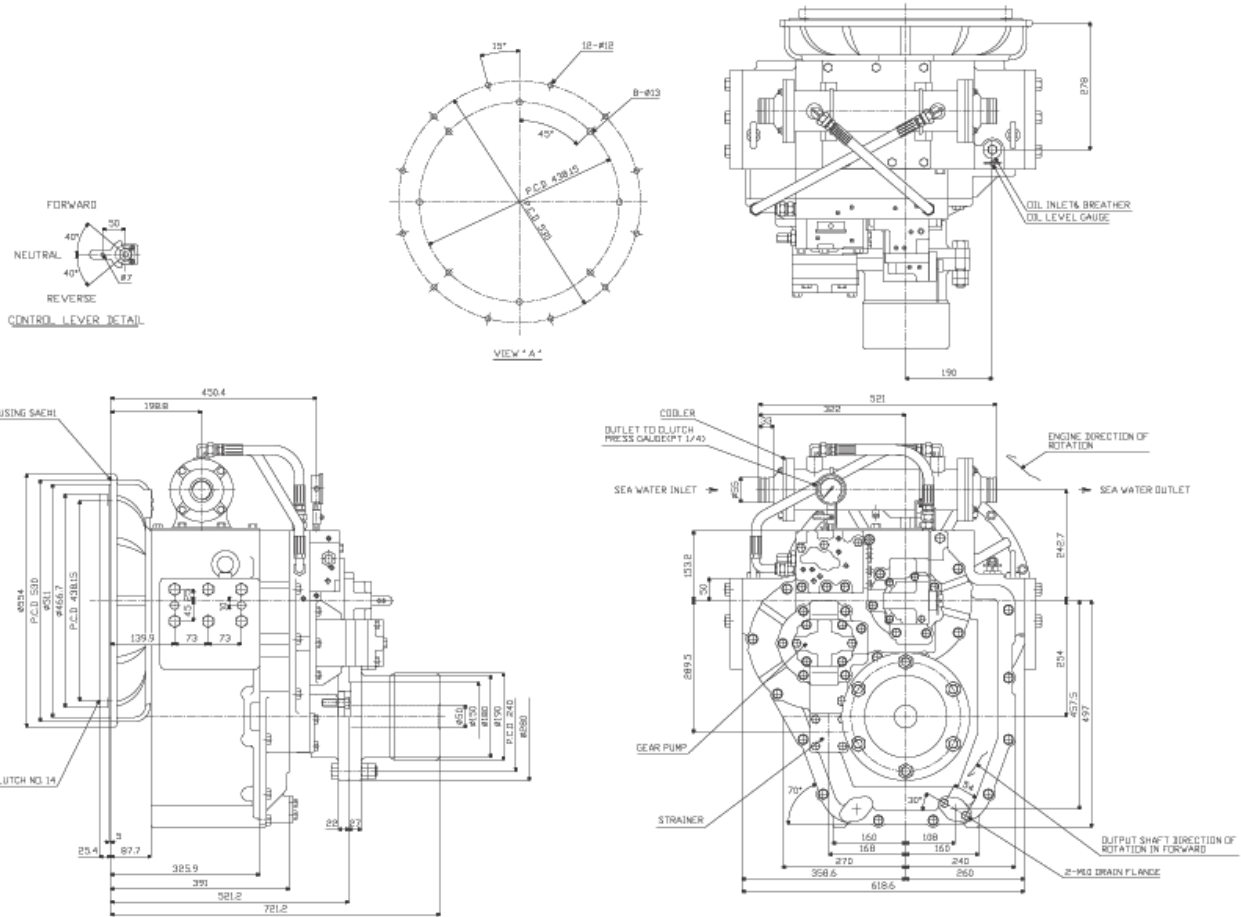

### PRECAUTIONS

- Align the center of engine with marine gear (For greater effectiveness and longer lifespan)
- Install the supporting bracket of marine gear.
- When assembling flange on output shaft of marine gear, be sure to align another flange accurately.
- Make sure to wash flywheel housing cover if dust should accumulate.
- When installing the cable and the remote-control level, check to make sure the marine gear level is smooth.
- The oil with the viscosity equivalent to SAE#30 is recommended.
- Check the oil amount of oil before sailing.
- After 100 hours of operation check the oil, and then change every 1,000 hours.

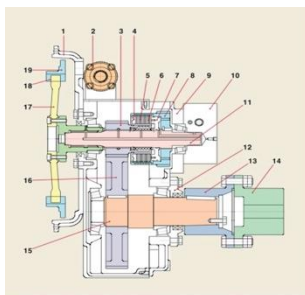

#### SECTIONAL DRAWING

- |                   |                       |
|-------------------|-----------------------|
| 1 Wheel Cover     | 11 Input Shaft        |
| 2 Oil Cooler      | 12 Retainer Cover     |
| 3 Pinion Gear     | 13 Coupling           |
| 4 Plate, Side     | 14 Coupling Companion |
| 5 Plate, Sintered | 15 Output Shaft       |
| 6 Plate, Steel    | 16 Reduction Gear     |
| 7 Piston          | 17 Spider             |
| 8 Drum Gear       | 18 Rubber Block       |
| 9 Block Cover     | 19 Rubber Ring        |
| 10 Control Block  |                       |

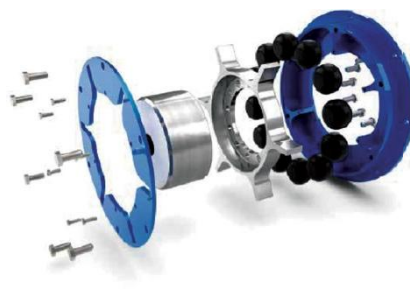

### ADVANTAGES OF FLEXIBLE COUPLING

- 01 Plug-in Connection
- 02 Heat-Resistant up to 130°C
- 03 Fail-safe solution
- 04 Lubrication free
- 05 Rubber block solution