

- Compact Design
- Enhanced engine power / Durability
- Low Fuel / Oil Consumption
- Easy Maintenance

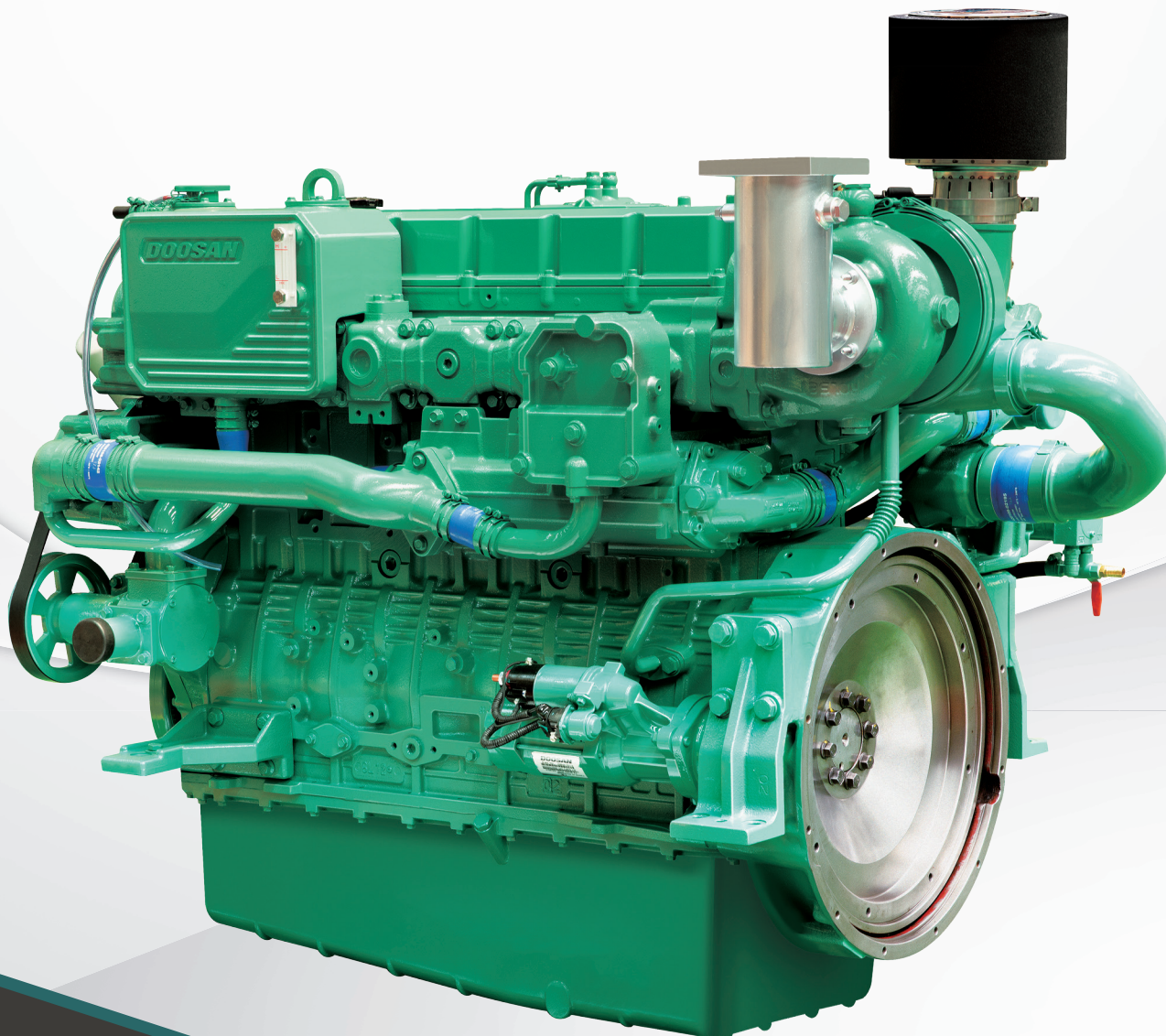

## *Marine Diesel Engine*

# 4L126TI

- ◆ Rating output : H : 331kW (450PS) / M : 364kW (495PS) / L : 401kW (545PS)
- ◆ Displacement : 11,051 cc
- ◆ Dimension (L x W x H) : 1131mm x 904mm x 1153mm (Without Reduction Gear)



Doosan Infracore Co., Ltd.

<http://engine.doosaninfracore.co.kr>

Doosan Tower 28TH FL. 275, Jangchungdan-Ro(St),  
Jung-Gu, Seoul, 04563 Korea

Tel : +82 2 3398 8851 / Fax : +82 2 3398 8898

E-mail : [enginesales@doosan.com](mailto:enginesales@doosan.com)



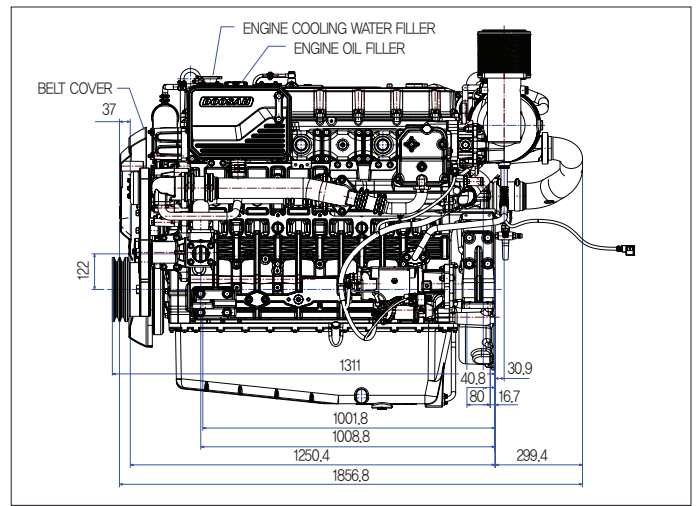
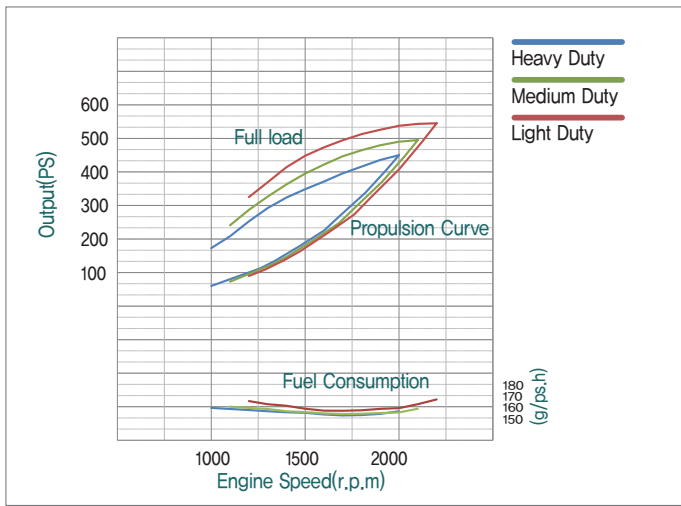

## Marine rating to ISO 3046

### Heavy Duty

- Operation hours : unlimited per year, unlimited per day
- Average load application : up to 90% • Percentages of time at full load : up to 80%
- Typical gearbox ratio : 2.5 ~ 6

\* Application : Fishing trawler, Tug boat, Pushing vessel, Cargo boat, Freighter

### Medium Duty

- Operation hours : up to 3,000hr per year, up to 10hrs per day
- Average load application : up to 70%
- Percentages of time at full load : up to 30%
- Typical gearbox ratio : 2 ~ 3.5

\* Application : Pilot boat, Escort boat, Passenger boat, Freighter, Ferry, Cruising vessel

### Light Duty

- Operation hours : up to 1,000hr per year, up to 5hrs per day
- Average load application : up to 50% • Percentages of time at full load : up to 20%
- Typical gearbox ratio : 1 ~ 2.5

\* Application : Yacht, Cruising vessel, Fast boat, Fire pump

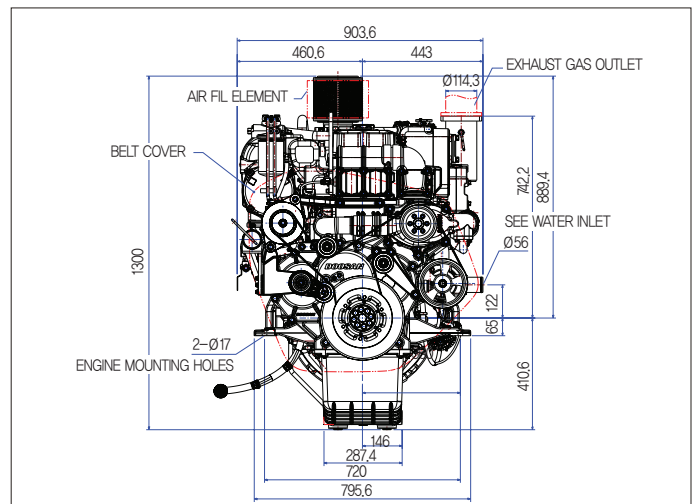

## Main Specification

Model	Units	4L126TI		
		4L126TIH	4L126TIM	4L126TIL
Engine type		4Cyl, In line, Direct-Injection, Water Cooled with turbo charger & Inter-cooler		
Rating output	PS(kW) / rpm	450(331) / 2000	495(364) / 2100	545(401) / 2200
Displacement	cc	11,051		
Cylinder number – bore x stroke	mm	6–123 x 155		
Flywheel housing & fly wheel		SAE 1 & 14		
Low idling rpm	rpm	725±25		
No load max. rpm	rpm	below 2200	below 2300	below 2400
Compression ratio		16.7:1		
Firing order		1–5–3–6–2–4		
Governor type of injection pump		Mechanical Variable Speed (R,S,V)		
Fuel consumption (only Ref.) @rated power	g / PS.h	157	166	173
	Lit. / h	84	93	108
Starting system		Electric Starting by starter motor		
Starter motor capacity	V – kW	24 – 6.0		
Alternator capacity	V – A	24 – 80		
Battery	V – Ah	12 – 150		
Cooling system		Indirect sea water cooling with heat exchanger		
Cooling water capacity	Max / Min	Lit. 48 / 45		
Fresh water pump type		Centrifugal (Pulley type)		
Sea water pump type		Rubber Impeller		
Lubricating oil (Engine)	Pan capacity	Lit. Max : 44, Min : 20 (Engine Total 47)		
	Pressure	kg / cm <sup>2</sup> Full : 3.0, Idle : 1.0		
Direction of revolution	crankshaft	Counter clockWise viewed from stern side		
Engine size (L x W x H)	without M / G	mm 1311 x 904 x 1153		
Engine dry weight	without M / G	kg 1136		