

6AYM-WET

H-rating 555kW (755mhp)

MARINE
PROPULSION
DIESEL ENGINE



- 6-cylinder, direct injection, heat exchanger cooling.
- Turbocharger + intercooler.
- 4-valves per cylinder for higher combustion efficiency.
- Available either with marine gear or without marine gear.
- Conform to IMO Tier II emissions regulations.

Specifications

Model	6AYM-WET H-rating	
Number of cylinders	6 in-line	
Bore × stroke	mm	155 × 180
Displacement	lit.	20.379
Rated output	kW(hp)/rpm	H : 555(755)/1840
Combustion system	Direct injection	
Aspiration	Turbocharger + intercooler	
Starting system	Electric starting motor (24V 7.0kW)	
Cooling system	Heat exchanger	
Size of flywheel housing and flywheel	SAE #0 and 18 in.	
Dry mass	kg	2365 (without marine gear)
Dimensions (L×W×H)	mm	2000×1305×1431

Marine gear specifications

Engine model : 6AYM-WET H-rating		
Model	YXH-240	YXH-240L
Type	Hydraulic multi-disc clutch	
Reduction ratio (Ahead)	1.95 2.27 2.56 3.03 3.48	4.13 4.48 4.89 5.36 5.91 6.57 6.95
Direction of rotation (propeller shaft)	Clockwise or counterclockwise	
Dry weight	kg	645 1240

Dimensions Unit:mm

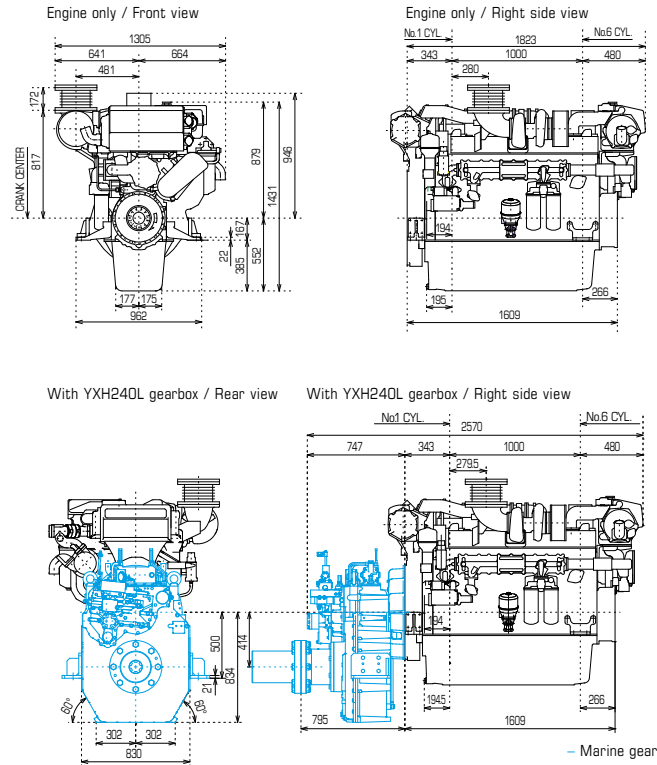

Performance curves

