



powering **marine** safety

BUKH V8-400

DIESEL PERFORMANCE
400 HP (294 KW)

The BUKH V8 6.6L is a powerful and compact light weight diesel engine that are designed to suit all commercial and leisure applications. With the strong Duramax base engine and Marinization done by BUKH in Denmark, the BUKH V8 is the right choice when reliability, performance, compact and quality is the key-words for your project.



TECHNICAL DESCRIPTION:

ENGINE BLOCK AND HEAD

- Cast iron cylinder block - Induction hardened for increased durability
- Nitride hardened steel crankshaft
- One piece hot forged steel connection rods
- Aluminum cylinder heads
- 4 valves per cylinder
- Frontend gear train

ENGINE MOUNTING

- Flexible engine mounting

LUBRICATION SYSTEM

- Crankcase ventilation system
- Oil filter relocater / remote filter bracket

FUEL SYSTEM

- External fuel filter for remote or on engine install
- Fuel cooler installed on engine
- Bosch CP3 common rail system
- Pilot injections to reduce combustion noise

AIR INLET AND EXHAUST SYSTEM

- Exhaust manifolds made of high quality cast aluminium
- Wet exhaust elbow
- Intake assembly with integrated stainless steel inter-cooler
- Variable geometry turbo (VGT)

COOLING SYSTEM

- Freshwater-cooled charge air cooler
- Seawater cooled heat exchanger
- Coolant system prepared for hot water outlet
- Easily accessible seawater pump front of engine
- Steering oil cooler prepared on engine

ELECTRICAL SYSTEM

- 12V alternator
- 24 V alternator (optional)
- Dual alternator (optional)
- Dual electric starter (Optional)
- Glowplugs (Optional)
- Extra alternator (Optional)

INSTRUMENTS/CONTROLS

- Engine date on 3,5" display
- Laptop based diagnostics tool
- J1939 and NMEA2000 can communication
- Display IP 66 protection (front)

BUKH V8-400

DIESEL PERFORMANCE



BUKH V8-400 Specifications

Engine type	V8
Engine duty rating	C7 -Special Light Duty Commercial_2
Crankshaft power [hp(kW)]	400 (294)
Rpm@full load	3600
Cylinders	V8
Displacement [L]	6,6
Bore [mm]	103
Stroke [mm]	98
Compression ratio	16.8:1
Injection system	Bosch common rail
Firing order	1-2-7-8-4-5-6-3
Electronic engine diagnostic	YES
Max. torque, NM @ 2100 rpm	750
Dry Weight Bobtail [kg]	510
Propulsion system	Waterjet, Shaft-, Stern- & Surface drive

As BUKH is always endeavouring to improve the engines, specifications mentioned are subject to alterations without previous notice.

V8-400 Dimensions

Not for installation

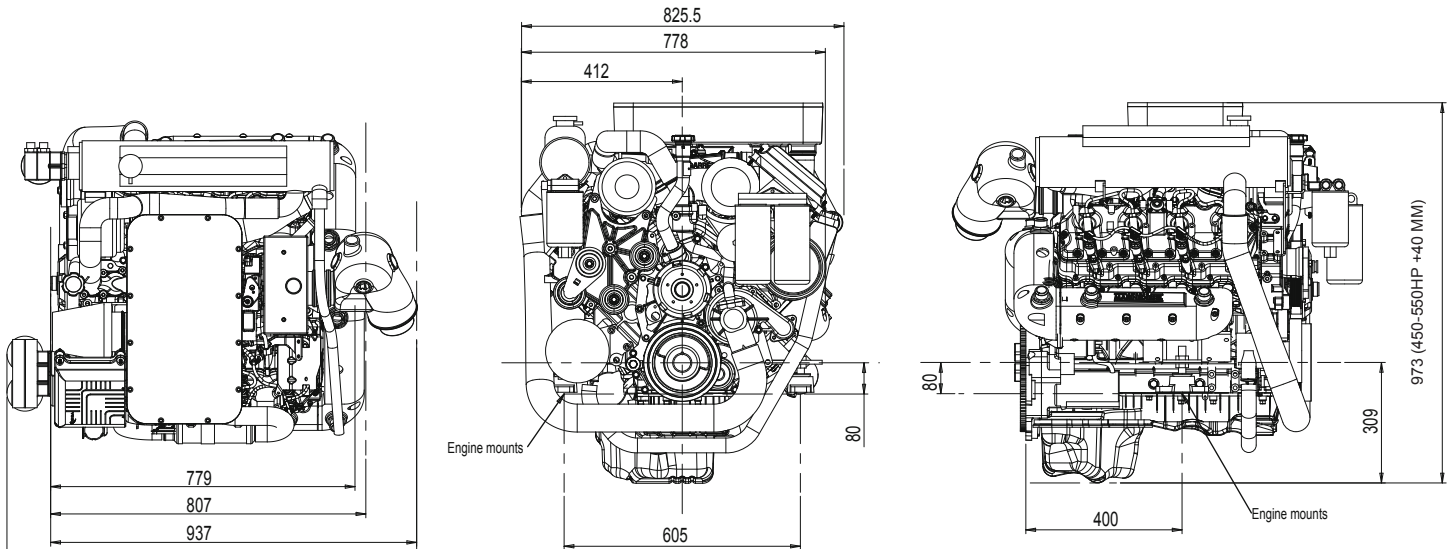

Peak Torque* and Hp* vs. RPM

