

S12H SERIES

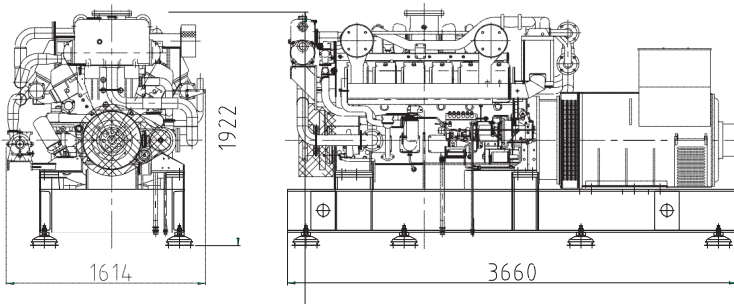

1100 kVA - 1425 kVA
1500 RPM - 50 Hz.



TECHNICAL DATA

Engine brand Mitsubishi
Engine designation S12H-PTA
No. of cylinders and configuration . . . V 12
Method of operation 4-stroke,
. direct-injected, turbocharged
. diesel engine with aftercooler
Bore, mm 150
Stroke, mm 160
Displacement, l 33.93
Compression ratio 14.5:1
Crankshaft Power HE Cooling
at 1500 rpm, kW (hp) 709 (964)
at 1800 rpm, kW (hp) 828 (1126)
Crankshaft Power KC Cooling
at 1500 rpm, kW/(hp) 709 (964)
at 1800 rpm, kW (hp) 828 (1126)
Recommended fuel to conform to
. ASTM No. 2-D
Specific fuel consumption best point,
g/kWh at 1500 rpm 204 (75%)
g/kWh at 1800 rpm 218 (100%)

All data represent net performance with standard accessories such as fuel injection pump, water pump, L.O. pump and charging alternator under the conditions of 100kPa (750mm Hg), barometric pressure 300K (27°C) ambient temperature and 60% relative humidity.
The engine is certified acc. to IMO NOx, stage 2.

ENGINE

The Mitsubishi engines are well balanced and have excellent emission performance, meeting all present and coming emission regulations, including IMO stage 2 and CCNR .

Mitsubishi's basic design in combination with Woodward governor and a modern electronic control system gives superior load acceptance and synchronizing capabilities, meeting all standards with good margin .

GENERATOR

All the standard Gensets are equipped with a generator built by Newage Stamford . Stamford is the market leader in this power range and provides for worldwide service coverage . These generators are of a long proven design, based on years of experience of power generation for land-based and marine applications .

STANDARD SPECIFICATION

Heavy-duty, water-cooled diesel engine
Radiator with mechanical fan
Protective grille for fan and rotating parts
Electric starter and charge alternator
Starting battery (with lead acid) including rack and cables
Engine jacket water heater
Steel base frame and anti-vibration isolators
Fuel tank under the base frame
Flexible fuel connection hoses
Single bearing, class H alternator
Industrial exhaust silencer and steel bellows supplied separately
Static battery charger
Manual for application and installation
Generators Sets' voltage and frequency regulation comply with ISO 8528-5
Generators Sets' can take 100% load at one step according to NFPA110

GENERAL CHARACTERISTICS

Frequency (Hz) 50
Control Panel Model 7320
Model Name APD 825 M
Fuel Type Diesel

Technical description

Complete Genset

- High system efficiency as a result of system optimization of the complete Genset
- All used components of highest quality from well reputed suppliers
- Reinforced set dimensioned for high output and low sound level
- Mono-block engine/generator rigidly mounted on a common bed frame
- Engine directly coupled to generator via a flexible coupling
- Flexible mountings including welding plates mounted under the frame
- Full protection of rotating parts will be provided

Engine

- Flywheel housing with connection acc. to SAE 0
- Flywheel (18")
- Engine brackets

Lubrication system

- Freshwater-cooled oil cooler
- Spin-on type oil filters with change over valve
- Spin-on type oil by-pass filter

Fuel system

- Woodward electronic or hydraulic governing systems
- Jacketed fuel pipes
- Spin-on type fuel filters of change over type
- 24V fuel shut-off valve, electrically operated

Inlet air and exhaust system

- Non-cooled turbocharger
- Air inlet filter/silencer
- Fresh water cooled charge air cooler. (on MPTA models)

Other equipment

- Front P.T.O. pulley (2x B groove)
- Front safety cover

Generator

- Temperature rise class H, ambient temp. 50 degr. C
- Anti condensation heating
- Droop kit

- Stator winding as standard with short 2/3 pitch winding, ideal for non-linear load (thyristor load)
- 4-pole, brushless, AC marine generator
- Dynamically balanced rotor
- Automatic Voltage Regulator (AVR) for accurate Voltage regulation
- Permanent magnet mounted on generator for independent power supply to AVR
- Permanent magnet system to obtain hard performance on motor start and to deliver stationary short circuit current
- Heavy damper cage for parallel operation and very low subtransient reactance values
- Double bearing generator as standard
- Voltage available range up to 690V
- IP23 enclosure as standard

Optional equipment

Engine

- Twin fuel filters/water separator with change over valve
- Flexible exhaust compensator, dry
- Raw/sea water circulation pump
- Cooling water connection bellows
- Electrical or air starting systems
- Engine cooling water heater 230V or 400 V
- Pre-lube oilpump combined with heater

Heat Exchanger cooled system (HE)

- For seawater- and central-cooled Gensets
- Plate heat exchanger with integrated expansion tank

Radiator cooled system (RC)

- For air-cooled Gensets
- V-belt-driven radiator fan

Keel cooled system (KC)

- 2-circuit keel cooling system for keel- or box coolers

ComAp Classified control and monitoring system

- Alarm and monitoring functions according to classification
- Optional functions on request
- Modbus
- Configurable inputs and outputs
- RPU-Shutdown unit, includes all shutdown functions required by classification societies

Generator

- Air inlet louvres/filters according to IP44
- Thermistors (1 or 2 per phase) mounted in generator for temperature measurement of windings in generator
- PT100 elements (1 or 2 per phase) mounted in generator for temperature measurement of windings in generator
- Single bearing generator
- PT100 elements mounted in generator bearings for temperature measurement
- Water cooled generator

Miscellaneous

- Flexible exhaust compensator
- Dry exhaust silencer with or without spark arrestor
- Synchronizer unit
- Load sharing unit
- Toolkit
- Spare parts according to classification recommendations

Contact your local dealer for further information.

Not all models, standard equipment and accessories are available in all countries. All specifications are subject to change without notice.

The Genset illustrated may not be entirely identical to production standard Gensets.

Technical data HE-KC Genset

847 kVA (678kWe)/ 1500 rpm 50 Hz 988 kVA (790 kWe) / 1800 rpm 60 Hz
Dimensions L x W x H, mm, not for installation

S12H-PTA.3660x1614 x 1922

Dry weight, complete set. 6000 kg

GeneratorHCM 634 J2

All data represent net performance with standard accessories such as fuel injection pump, water pump, L.O. pump and charging alternator under the conditions of 100kPa (750 mm Hg), barometric pressure 300K (27° C) ambient temperature and 60% relative humidity.

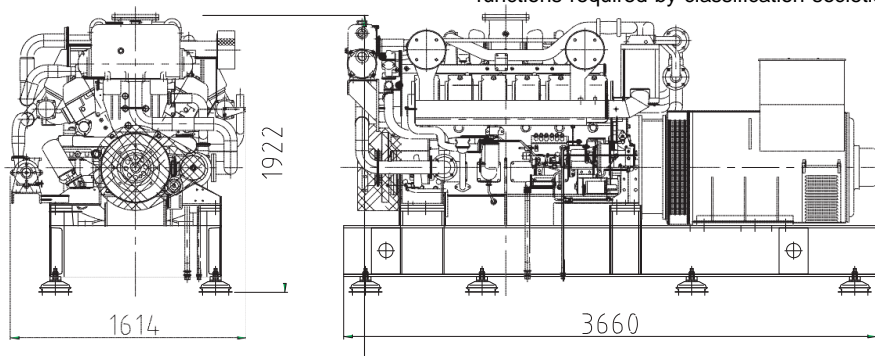

Control Module DSE Model 7320

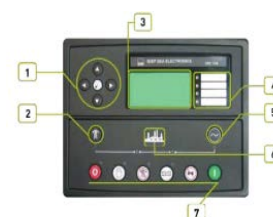

1. MENU NAVIGATION BUTTONS
2. CLOSE MAINS BUTTON
3. MAIN STATUS BUTTON
4. ALARM LED'S
5. CLOSE GENERATOR BUTTON
6. STATUS LED'S
7. OPERATION SELECTING BUTTONS

APPENDIX

- POWER RANGE ALL MODELS

Emission - Unregulated | High Speed > 100 kWm

	Output ¹				Engine Speed rpm	Frequency Hz
	Standby		Prime			
	kWm	kVA	kWm	kVA		
S6B3-PTA	359	426	324	385	1500	50
S6A3-PTA	430	511	390	463	1500	50
S6A3-PTAA	463	550	420	499	1500	50
S6R-PTA	555	659	500	594	1500	50
S6R2-PTA	635	754	575	683	1500	50
S6R2-PTAA	710	843	645	766	1500	50
S12A2-PTA	723	859	656	799	1500	50
S12A2-PTA2	818	971	742	881	1500	50
S12H-PTA	980	1164	890	1057	1500	50
S12R-PTA	1190	1413	1080	1283	1500	50
S12R-PTA <small>Switchable</small>	-	-	1110	1318	1500	50
S12R-PTA2	1285	1526	1165	1383	1500	50
S12R-PTAA2	1441	1711	1314	1560	1500	50
S16R-PTA	1590	1888	1450	1722	1500	50
S16R-PTA2	1760	2090	1600	1900	1500	50
S16R-PTAA2	1939	2303	1728	2052	1500	50
S16R2-PTAW	2167	2573	1960	2328	1500	50
S16R2-PTAW-E	2275	2702	2068	2456	1500	50
S16R2-PTAW2-E	2430	2886	2209	2623	1500	50

- GENSET DIMENSIONS S12H GENSET WITH OR WITHOUT CANOPY

Open Gen. Set Dimensions (mm)		Gen. Set Canopy Dimensions (mm)	
LENGHT	3660	LENGHT 5410	6500
WIDTH	1640	WIDTH 1860	2200
HEIGHT	1922	HEIGHT 2650	2350
DRY WEIGHT (kg.)	6965	DRY WEIGHT (kg.) 7680	9840
TANK CAPACITY (lt.)	850/1500	TANK CAPACITY (lt.) 1300	800/1500