

# S12R SERIES

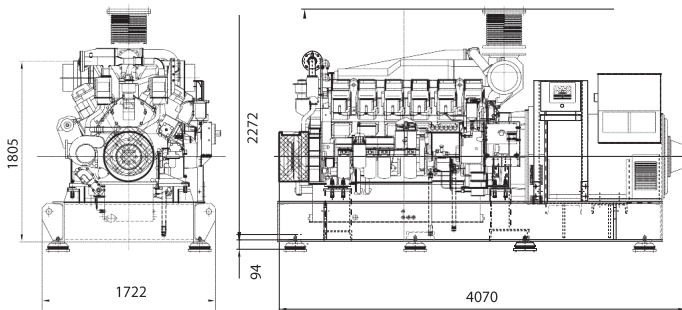

**1351 kVA (1081kWe) / 1500 rpm 50 Hz**  
**1529 kVA (1223kWe) / 1800 rpm 60 Hz**

## TECHNICAL DATA

Engine brand ..... Mitsubishi  
Engine designation ..... S12R-Z3MPTAW  
No. of cylinders and configuration . . . V 12  
Method of operation . . . . . 4-stroke,  
. . . . . direct-injected, turbocharged  
. . . . . diesel engine with aftercooler  
Bore, mm..... 170  
Stroke, mm..... 180  
Displacement, l.....49.03  
Compression ratio..... 14:1  
Crankshaft Power HE Cooling  
at 1500 rpm, kW (hp) . . . . . 1120 (1523)  
at 1800 rpm, kW (hp) . . . . . 1270 (1727)  
Crankshaft Power KC Cooling  
at 1500 rpm, kW (hp). . . . . 1120 (1523)  
at 1800 rpm, kW (hp). . . . . 1270 (1727)  
Recommended fuel to conform to . . . . .  
. . . . . ASTM No. 2-D  
Specific fuel consumption best point,  
g/kWh at 1500 rpm . . . . . 208 (100%)  
g/kWh at 1800 rpm . . . . . 208 (100%)

All data represent net performance with standard accessories such as fuel injection pump, water pump, L.O. pump and charging alternator under the conditions of 100kPa (750mm Hg), barometric pressure 300K (27°C) ambient temperature and 60% relative humidity.

The engine is certified acc. to IMO NOx, stage 2.

## ENGINE

The Mitsubishi engines are well balanced and have excellent emission performance, meeting all present and coming emission regulations, including IMO stage 2 and CCNR.

Mitsubishi's basic design in combination with Woodward governor and a modern electronic control system gives superior load acceptance and synchronizing capabilities, meeting all standards with good margin.

## GENERATOR

All the standard Gensets are equipped with a generator built by Newage Stamford. Stamford is the market leader in this power range and provides for worldwide service coverage. These generators are of a long proven design, based on years of experience of power generation for land-based and marine applications.

## STANDARD SPECIFICATION

Heavy-duty, water-cooled diesel engine  
Radiator with mechanical fan  
Protective grille for fan and rotating parts  
Electric starter and charge alternator  
Starting battery (with lead acid) including rack and cables  
Engine jacket water heater  
Steel base frame and anti-vibration isolators  
Fuel tank under the base frame  
Flexible fuel connection hoses  
Single bearing, class H alternator  
Industrial exhaust silencer and steel bellows supplied separately  
Static battery charger  
Manual for application and installation  
Generators Sets' voltage and frequency regulation comply with ISO 8528-5  
Generators Sets' can take 100% load at one step according to NFPA110

## GENERAL CHARACTERISTICS

Frequency (Hz) 50  
Control Panel Model 7320  
Model Name APD 825 M  
Fuel Type Diesel

## Technical description

### Complete Genset

- High system efficiency as a result of system optimization of the complete Genset
- All used components of highest quality from well reputed suppliers
- Reinforced set dimensioned for high output and low sound level
- Mono-block engine/generator rigidly mounted on a common bed frame
- Engine directly coupled to generator via a flexible coupling
- Flexible mountings including welding plates mounted under the frame
- Full protection of rotating parts will be provided

### Engine

- Flywheel housing with connection acc. to SAE 0
- Flywheel (18")
- Engine brackets

### Lubrication system

- Freshwater-cooled oil cooler
- Spin-on type oil filters with change over valve
- Spin-on type oil by-pass filter

### Fuel system

- Woodward electronic or hydraulic governing systems
- Jacketed fuel pipes
- Spin-on type fuel filters of change over type
- 24V fuel shut-off valve, electrically operated

### Inlet air and exhaust system

- Non-cooled turbocharger
- Air inlet filter/silencer
- Fresh water cooled charge air cooler. (on MPTA models)

### Other equipment

- Front P.T.O. pulley (2x B groove)
- Front safety cover

### Generator

- Temperature rise class H, ambient temp. 50 degr. C
- Anti condensation heating
- Droop kit

- Stator winding as standard with short 2/3 pitch winding, ideal for non-linear load (thyristor load)
- 4-pole, brushless, AC marine generator
- Dynamically balanced rotor
- Automatic Voltage Regulator (AVR) for accurate Voltage regulation
- Permanent magnet mounted on generator for independent power supply to AVR
- Permanent magnet system to obtain hard performance on motor start and to deliver stationary short circuit current
- Heavy damper cage for parallel operation and very low subtransient reactance values
- Double bearing generator as standard
- Voltage available range up to 690V
- IP23 enclosure as standard

### Optional equipment

#### Engine

- Twin fuel filters/water separator with change over valve
- Flexible exhaust compensator, dry
- Raw/sea water circulation pump
- Cooling water connection bellows
- Electrical or air starting systems
- Engine cooling water heater 230V or 400 V
- Pre-lube oilpump combined with heater

#### Heat Exchanger cooled system (HE)

- For seawater- and central-cooled Gensets
- Plate heat exchanger with integrated expansion tank

#### Radiator cooled system (RC)

- For air-cooled Gensets
- V-belt-driven radiator fan

#### Keel cooled system (KC)

- 2-circuit keel cooling system for keel- or box coolers

#### ComAp Classified control and monitoring system

- Alarm and monitoring functions according to classification
- Optional functions on request
- Modbus
- Configurable inputs and outputs
- RPU-Shutdown unit, includes all shutdown functions required by classification societies

### Generator

- Air inlet louvres/filters according to IP44
- Thermistors (1 or 2 per phase) mounted in generator for temperature measurement of windings in generator
- PT100 elements (1 or 2 per phase) mounted in generator for temperature measurement of windings in generator
- Single bearing generator
- PT100 elements mounted in generator bearings for temperature measurement
- Water cooled generator

### Miscellaneous

- Flexible exhaust compensator
- Dry exhaust silencer with or without spark arrestor
- Synchronizer unit
- Load sharing unit
- Toolkit
- Spare parts according to classification recommendations

Contact your local dealer for further information.

Not all models, standard equipment and accessories are available in all countries. All specifications are subject to change without notice.

The Genset illustrated may not be entirely identical to production standard Gensets.

### Technical data HE-KC Genset

1351 kVA (1081kWe)/ 1500 rpm 50 Hz

1529 kVA (1223kWe) / 1800 rpm 60 Hz

Dimensions L x W x H, mm, not for installation

S12R-MPTK . . . . . 4591 x 1507 x 2014

Dry weight, complete set. . . . . 9300 kg

Generator . . . . . PM734 C2

All data represent net performance with standard accessories such as fuel injection pump, water pump, L.O. pump and charging alternator under the conditions of 100kPa (750 mm Hg), barometric pressure 300K (27°C) ambient temperature and 60% relative humidity.

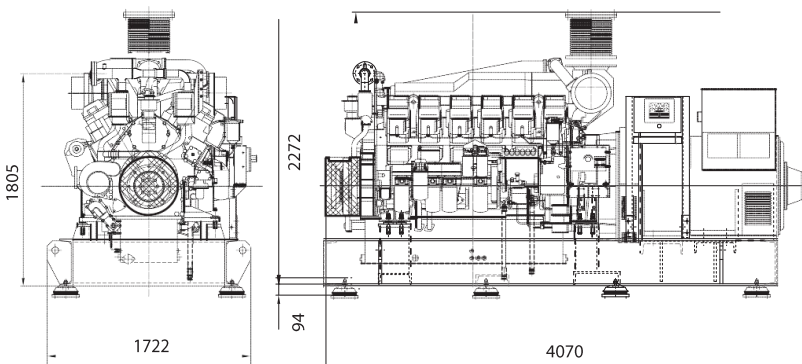

### Control Module DSE Model 7320

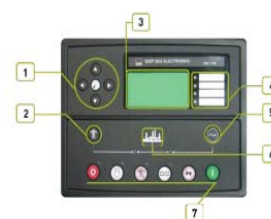

1. MENU NAVIGATION BUTTONS
2. CLOSE MAINS BUTTON
3. MAIN STATUS BUTTON
4. ALARM LED'S
5. CLOSE GENERATOR BUTTON
6. STATUS LED'S
7. OPERATION SELECTING BUTTONS

## - POWER RANGE ALL MODELS

## Emission - Unregulated | High Speed &gt; 100 kWm

	Output <sup>1</sup>				Engine Speed rpm	Frequency Hz
	Standby		Prime			
	kWm	kVA	kWm	kVA		
<b>S6B3-PTA</b>	359	426	324	385	1500	50
<b>S6A3-PTA</b>	430	511	390	463	1500	50
<b>S6A3-PTAA</b>	463	550	420	499	1500	50
<b>S6R-PTA</b>	555	659	500	594	1500	50
<b>S6R2-PTA</b>	635	754	575	683	1500	50
<b>S6R2-PTAA</b>	710	843	645	766	1500	50
<b>S12A2-PTA</b>	723	859	656	799	1500	50
<b>S12A2-PTA2</b>	818	971	742	881	1500	50
<b>S12H-PTA</b>	980	1164	890	1057	1500	50
<b>S12R-PTA</b>	1190	1413	1080	1283	1500	50
<b>S12R-PTA</b> <small>Switchable</small>	-	-	1110	1318	1500	50
<b>S12R-PTA2</b>	1285	1526	1165	1383	1500	50
<b>S12R-PTAA2</b>	1441	1711	1314	1560	1500	50
<b>S16R-PTA</b>	1590	1888	1450	1722	1500	50
<b>S16R-PTA2</b>	1760	2090	1600	1900	1500	50
<b>S16R-PTAA2</b>	1939	2303	1728	2052	1500	50
<b>S16R2-PTAW</b>	2167	2573	1960	2328	1500	50
<b>S16R2-PTAW-E</b>	2275	2702	2068	2456	1500	50
<b>S16R2-PTAW2-E</b>	2430	2886	2209	2623	1500	50

## - GENSET DIMENSIONS S12R GENSET WITH OR WITHOUT CANOPY

## Open Gen. Set Dimensions (mm)

LENGHT	4070
WIDTH	1722
HEIGHT	2272
DRY WEIGHT (kg.)	11400
TANK CAPACITY (lt.)	2000/2200

## Gen. Set Canopy Dimensions (mm)

LENGHT	9000
WIDTH	2800
HEIGHT	3300
DRY WEIGHT (kg.)	15450
TANK CAPACITY (lt.)	2000/2200