

Tolleranze secondo ISO 2548 classe C	Autoinnescante/Selfpriming		Tolerances according ISO 2548 C class
Velocità di rotazione [giri/min]	2000-2500-3000		Rotating speed [rpm]
Densità dell'acqua alla prova	1000	kg/m ³	Water density at test
Passaggio corpi solidi (max diametro sfera)	4.5	mm	Solid handling (max.diameter sphere)
Diametro girante	149	mm	Impeller diameter
Inerzia delle masse rotanti (innesto inserito)	0.01441	Kgm ²	Inerthia of rotating parts (engaged clutch)
Forza richiesta per l'azionamento dell'innesto	250	N	Clutch engaging effort
Altezza di innesco massima a 3000 giri/min	4.5	m	Maximum priming lift at 3000 rpm
Massa della pompa	32	kg	Pump mass

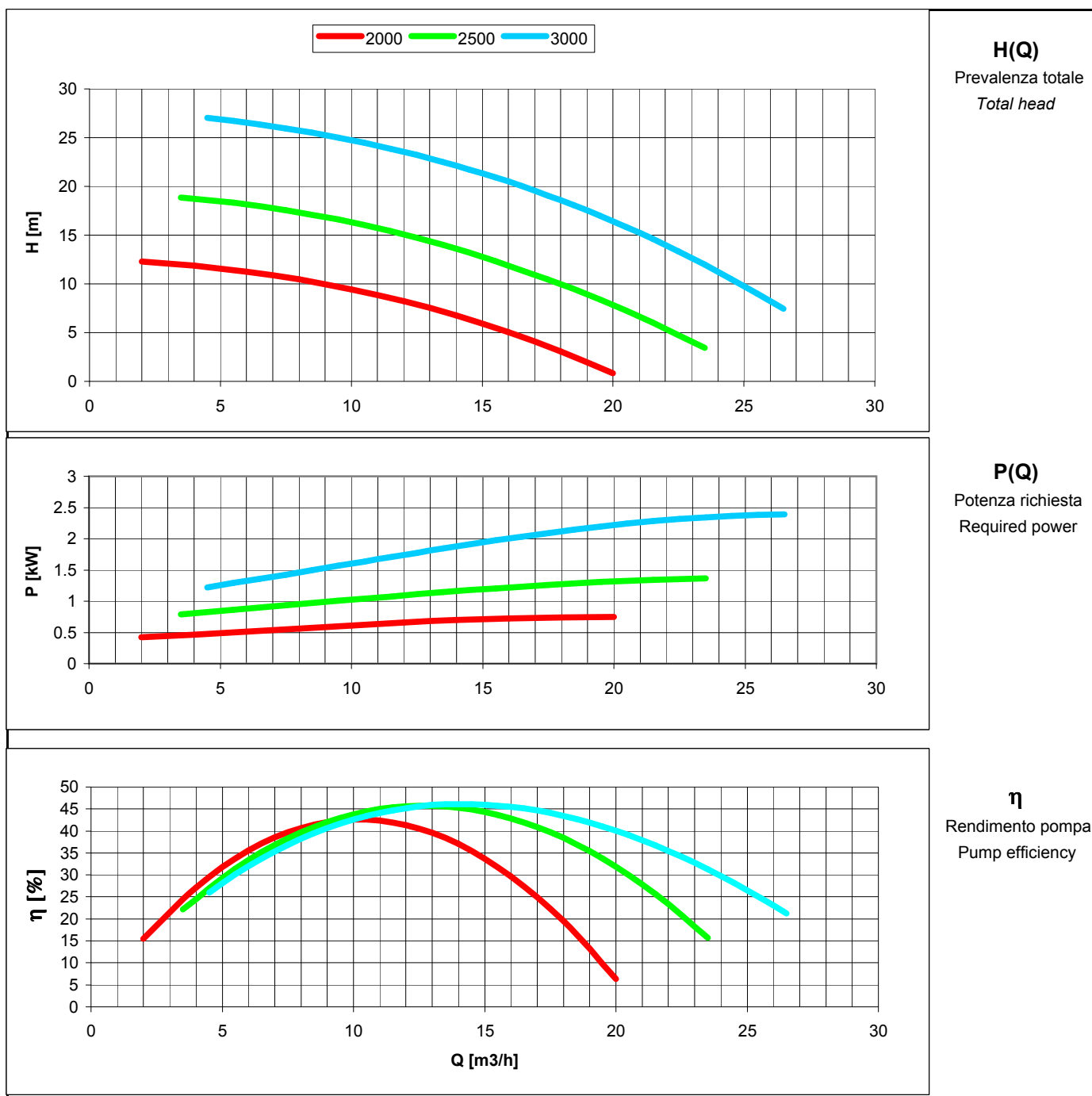

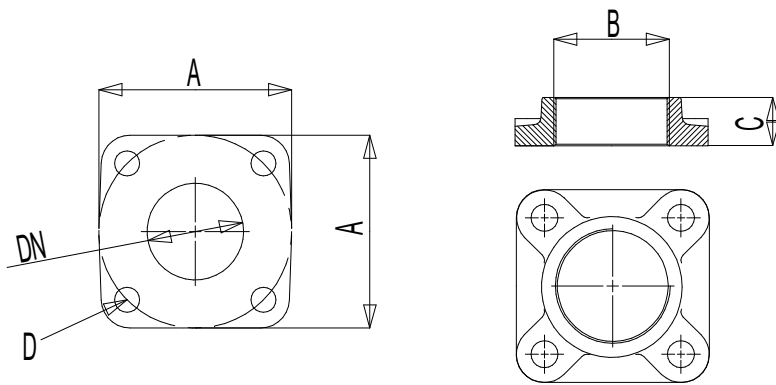

	DN	A	B	C	D
Mandata	40	100	1"1/2	26	Prigioniero M12
Aspirazione	50	100	2"	26	Prigioniero M12

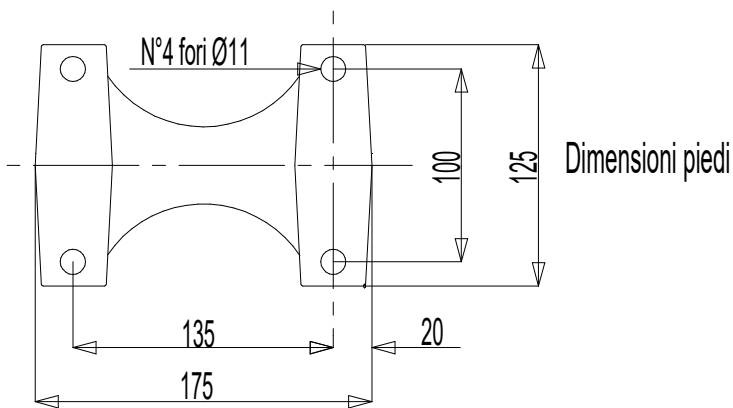
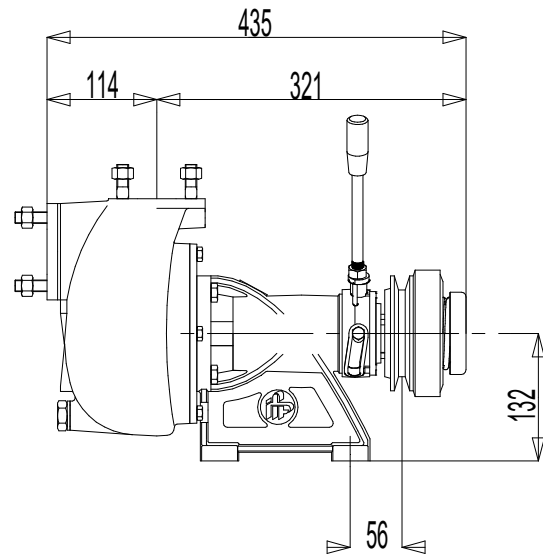
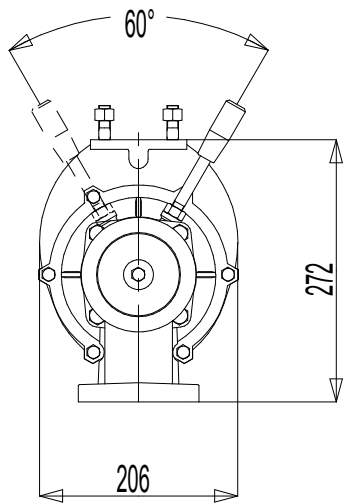